



DSD-J Series

DSD-H-J Series

CCT & 5 in 1 (Triac, 0-10V, 1-10V, 10V PWM, Potentiometer) Dim. C.V. J-Box LED Driver

(Output Voltage Fine Tune Available / 0-10V Double Signals & CCT(Warm Dim))

5 合 1 调光恒压双色壳机一体电源 【DSD-J · DSD-H-J 系列】 【输出电压可微调 / 0-10V 双信号调光调色】

Features

特性

- ★ **Dim-all:** CCT & Triac/0-10V/1-10V/10VPWM/Potentiometer
- **Universal input:** 110-277Vac
- **Dimming effect:**
 - PWM dim mode:** 100-0.1% dim, flicker-free
 - Triac dim mode:** Forward phase & reverse phase, MLV, ELV dim
- ★ **CCT-Tunable:** Linear adjustment of color temperature
0-10V signal X 2CH, Dimming & color temperature control
- With unique knob trim voltage function
- Wet, damp, and dry location,
- Title 24 JA8 compliant
- Build in active PFC, typical power factor>0.95, THD<10%@120V Max. load.
- Super low loading request, works perfect at 10-100% load.
- Short-circuit, over-temperature, over-load protection.
- UL cUL listed, Class 2, Class P, FCC, NEMA 4X, ROHS

- ★ **调光方式:** CCT可控硅/0-10V/1-10V/10V PWM/电阻调光
- 通用输入:** 110-277Vac
- 调光效果:**
 - PWM 调光模式:** 100-0.1% 调光, 无闪烁
 - 可控硅调光模式:** 正相和反相、MLV、ELV 调光
- ★ **CCT-Tunable:** 色温线性调光/
0-10V双信号调光和色温控制
- 具有独特的旋钮微调电压功能
- 适用于潮湿和干燥的位置
- 兼容Title 24, JA8标准
- 内置有源PFC, 典型功率因数>0.95, THD<10% @120V Max. load
- 超低负载要求, 在 10-100% 负载下完美运行
- 短路、过温、过载保护
- 认证:** UL/cUL, Class 2, Class P, FCC, NEMA 4X, ROHS

Selling Points

卖点

- 1) **PWM Output:** 4k/HZ Constant frequency
(Different frequencies can be customized:250-20000Hz)
- 2) **Dimming range:** 100%-0.1% Ultra Deep Amplitude
- 3) Works with two channel CCT warm-dim LED strip/tape (3 wires)
- 4) Exclusive patent design of "Clamshell" junction box
(Fixed without screws)

- 1) **PWM输出:** 4k/HZ恒定频率
(可定制不同频率: 250-20000Hz)
- 2) **调光范围:** 100%-0.1%超深幅度
- 3) 适用于两通道 CCT 冷暖调光LED灯条/3线芯LED 灯带
- 4) 独家 "Clamshell" 接线盒专利设计 (无需螺丝固定)

| Model 型号 | Cover Material 外壳材质 | Output Voltage 输出电压 (Vdc) | Output Current 输出电流 (Amp) | Output power 输出功率 (Watt) | Product Size 尺寸 (mm) | N/W 净重 (g) |
|--------------------|----------------------------|------------------------------|---------------------------------|--------------------------------|-------------------------|------------------|
| DSD-12030J | Metal Housing (NEMA 4X) | 12V(9-13Vadjustable) | 2.5A | 30W | 158*120.5*42 | 750 |
| DSD-24030J | | 24V(17-25Vadjustable) | 1.25A | | | |
| DSD-48030J | | 48V(36-49Vadjustable) | 0.63A | | | |
| DSD-12060J | | 12V(9-13Vadjustable) | 5A | 60W | 158*120.5*42 | 750 |
| DSD-24060J | | 24V(17-25Vadjustable) | 2.5A | | | |
| DSD-48060J | | 48V(36-49Vadjustable) | 1.25A | | | |
| DSD-12080J | | 12V(9-13Vadjustable) | 6.6A | 80W | 188*120.5*42 | 1100 |
| DSD-24080J | | 24V(17-25Vadjustable) | 3.3A | | | |
| DSD-48080J | | 48V(36-49Vadjustable) | 1.66A | | | |
| DSD-24096J | | 24V(17-25Vadjustable) | 4A | 96W | 188*120.5*42 | 1100 |
| DSD-48096J | | 48V(36-49Vadjustable) | 2A | | | |
| DSD-12100J | | 12V(9-13Vadjustable) | 8.33A | 100W | 188*120.5*42 | 1100 |
| DSD-24100J | | 24V(17-25Vadjustable) | 4.17A | | | |
| DSD-48100J | | 48V(36-49Vadjustable) | 2.08A | | | |
| DSD-12120J | | 12V(9-13Vadjustable) | 10A | 120W | 218*120.5*42 | 1100 |
| DSD-24120J | | 24V(17-25Vadjustable) | 5A | | | |
| DSD-48120J | | 48V(36-49Vadjustable) | 2.5A | | | |
| DSD-12150J | | 12V(9-13Vadjustable) | 12.5A | 150W | 218*120.5*42 | 1500 |
| DSD-24150J | | 24V(17-25Vadjustable) | 6.25A | | | |
| DSD-48150J | | 48V(36-49Vadjustable) | 3.125A | | | |
| DSD-12200J | | 12V(9-13Vadjustable) | 16.67A | 200W | 218*120.5*42 | 1500 |
| DSD-24200J | | 24V(17-25Vadjustable) | 8.33A | | | |
| DSD-48200J | | 48V(36-49Vadjustable) | 4.17A | | | |
| DSD-12300J | | 12V(9-13Vadjustable) | 25A | 300W | 258*120.5*42 | 1500 |
| DSD-24300J | 24V(17-25Vadjustable) | 12.5A | | | | |
| DSD-48300J | 48V(36-49Vadjustable) | 6.25A | | | | |
| High Power Class 2 | | | 120W-384W | | | |
| DSD-H12120J | Metal Housing (NEMA 4X) | 12V(9-13Vadjustable) | 2CH*5A | 2CH*60W | 218*120.5*42 | 1100 |
| DSD-H24120J | | 24V(17-25Vadjustable) | 2CH*2.5A | 2CH*60W | 218*120.5*42 | 1100 |
| DSD-H12180J | | 12V(9-13Vadjustable) | 3CH*5A | 3CH*60W | 218*120.5*42 | 1100 |
| DSD-H24192J | | 24V(17-25Vadjustable) | 2CH*4A | 2CH*96W | 218*120.5*42 | 1100 |
| DSD-H48192J | | 48V(36-49Vadjustable) | 2CH*2A | 2CH*96W | 218*120.5*42 | 1100 |
| DSD-H24288J | | 24V(17-25Vadjustable) | 3CH*4A | 3CH*96W | 258x120.5x42 | 1500 |
| DSD-H48288J | | 48V(36-49Vadjustable) | 3CH*2A | 3CH*96W | 258x120.5x42 | 1500 |
| DSD-H12300J | | 12V(9-13Vadjustable) | 5CH*5A | 5CH*60W | 258x120.5x42 | 1500 |
| DSD-H24384J | | 24V(17-25Vadjustable) | 4CH*4A | 4CH*96W | 258x120.5x42 | 1500 |
| DSD-H48384J | | 48V(36-49Vadjustable) | 4CH*2A | 4CH*96W | 258x120.5x42 | 1500 |

Wiring Diagram (Works with Two channel CCT warm-dim LED strip/tape (3 wires))

接线图 (适用于两通道 CCT 冷暖调光 LED 灯条/3线芯LED 灯带)

1) Using Triac / MLV wiring diagram 使用 Triac/MLV 接线图

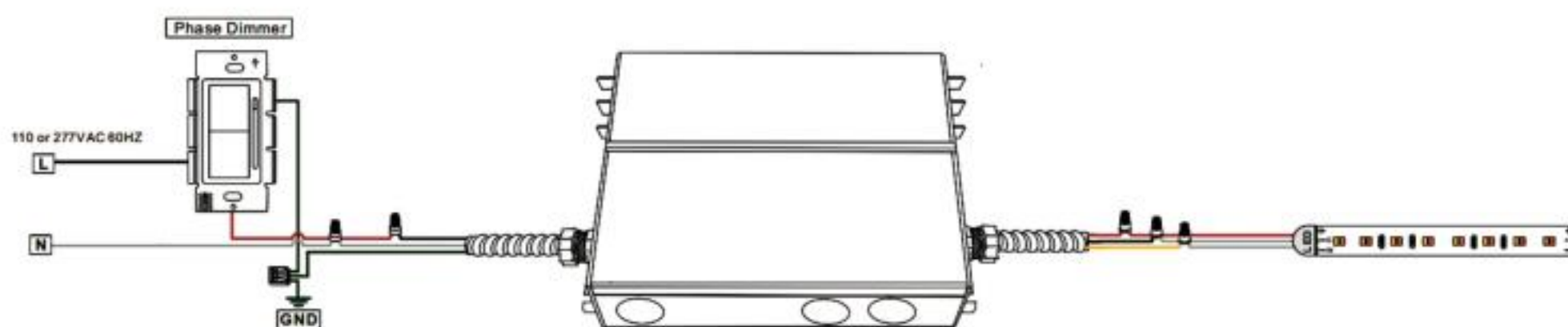

2) Using Triac / ELV wiring diagram 使用 Triac/ELV 接线图

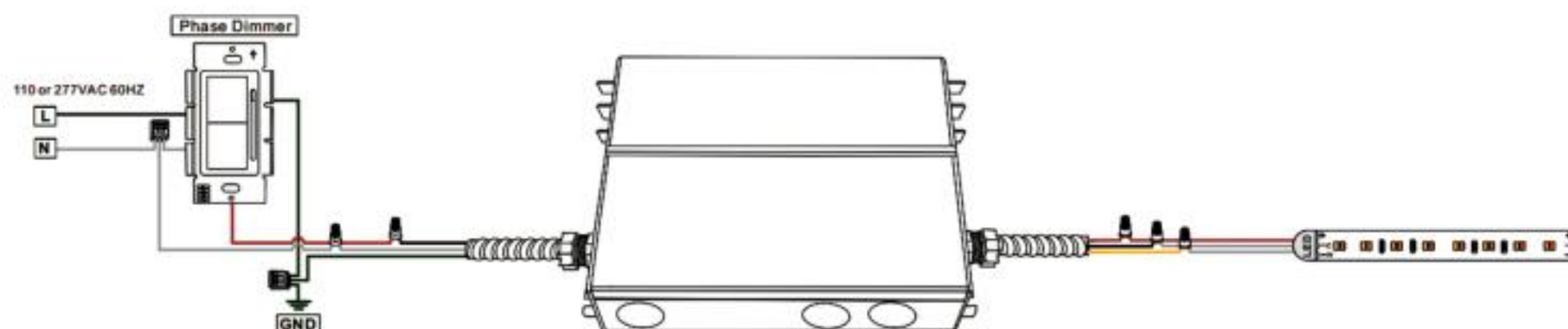

3) Using 0-10V/1-10V Dimming(The driver input is connected to the dimmer)

使用0-10V/1-10V调光 (驱动输入连接调光器)

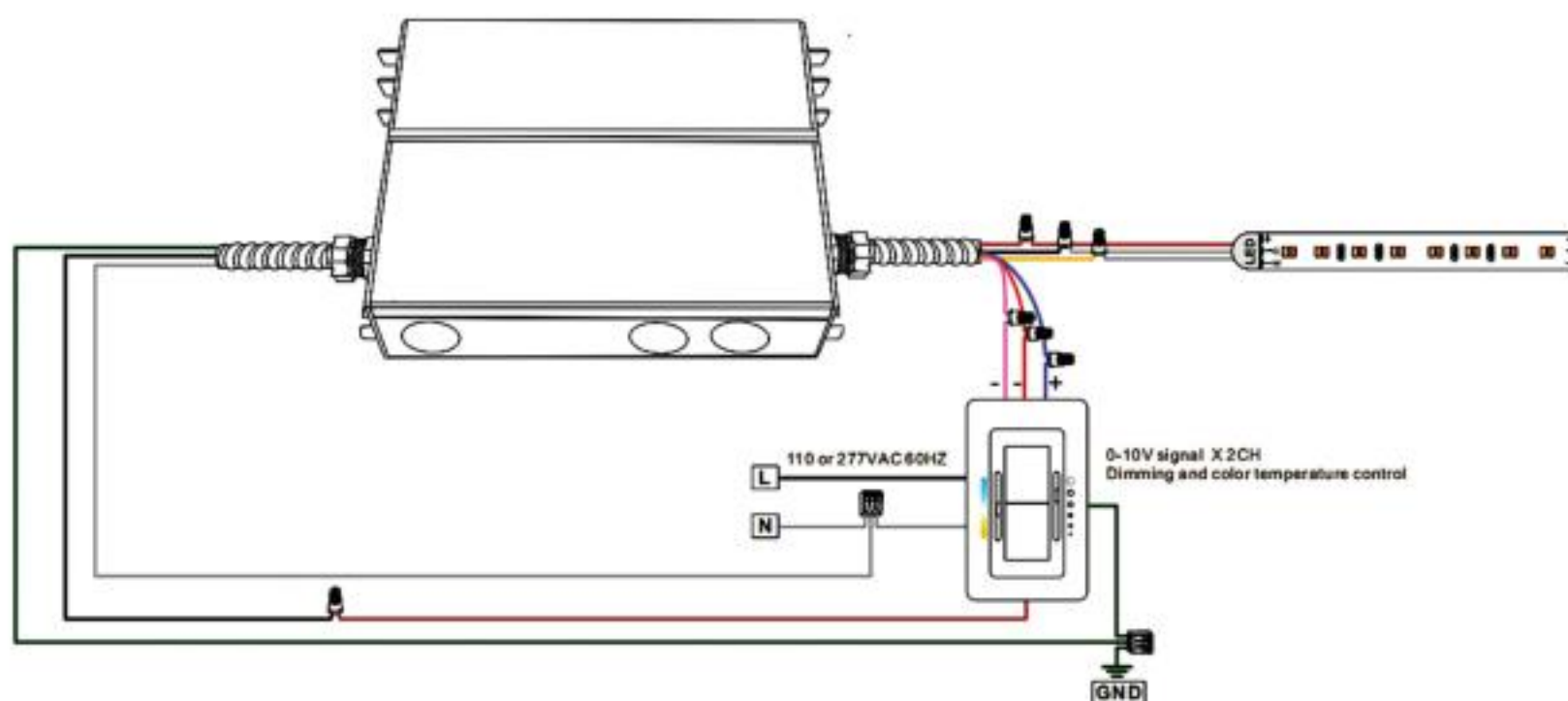

4) Using 0-10V/1-10V Dimming(The driver is independently connected to the input)

使用0-10V/1-10V调光 (驱动器独立连接输入)

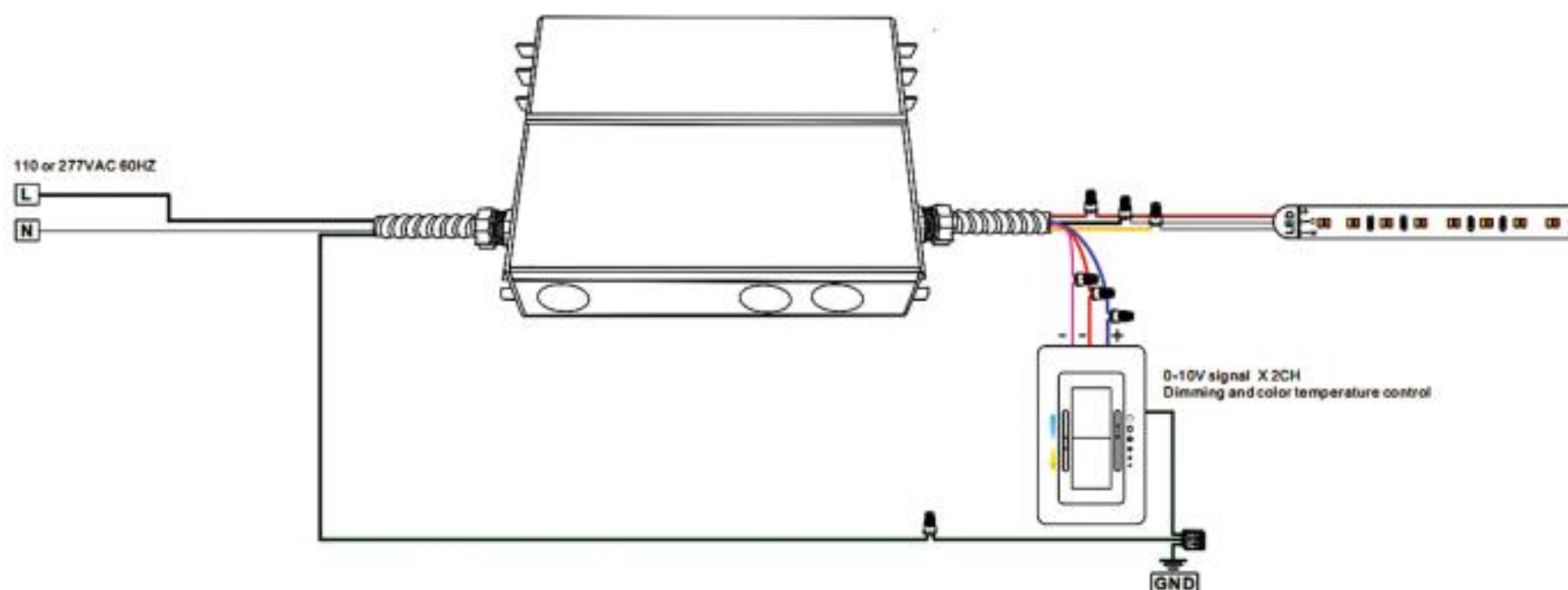

Wiring Diagram (e.g.: Following is the wiring diagram of high power class 2 LED Driver 384W)

接线图 (例如：以下是大功率 Class 2 LED驱动器384W接线图)

1) Using Triac / MLV wiring diagram 使用 Triac/MLV 接线图

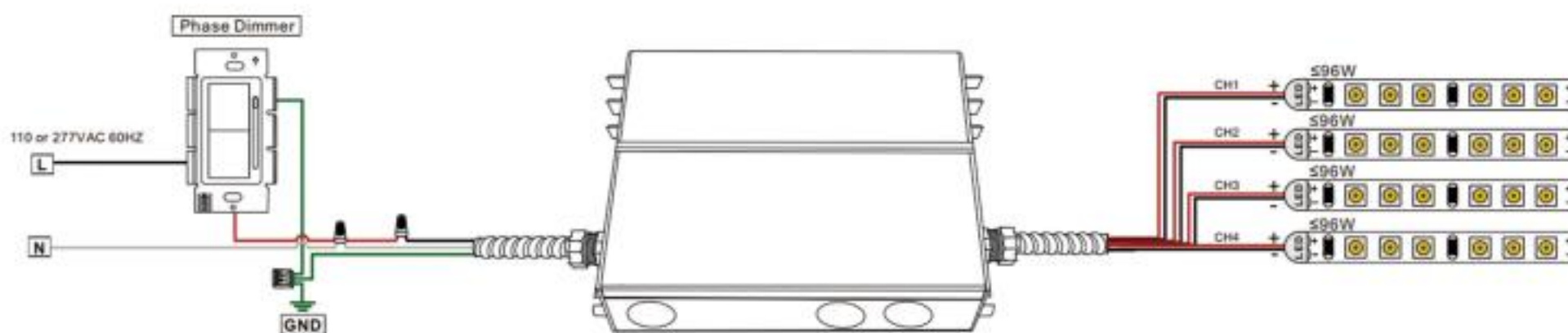

2) Using Triac / ELV wiring diagram 使用 Triac/ELV 接线图

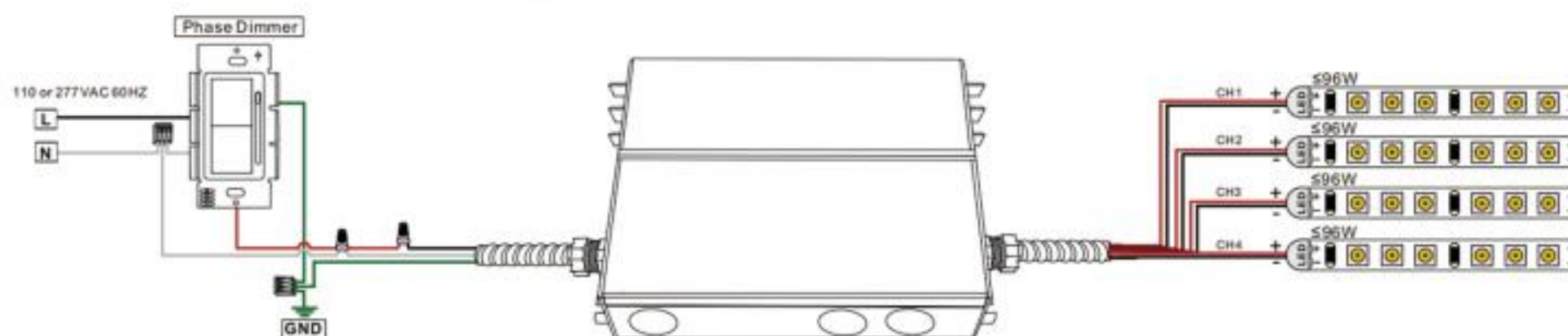

3) Using 0-10V/1-10V Dimming(The drive input is connected to the dimmer)

使用0-10V/1-10V调光 (驱动输入连接调光器)

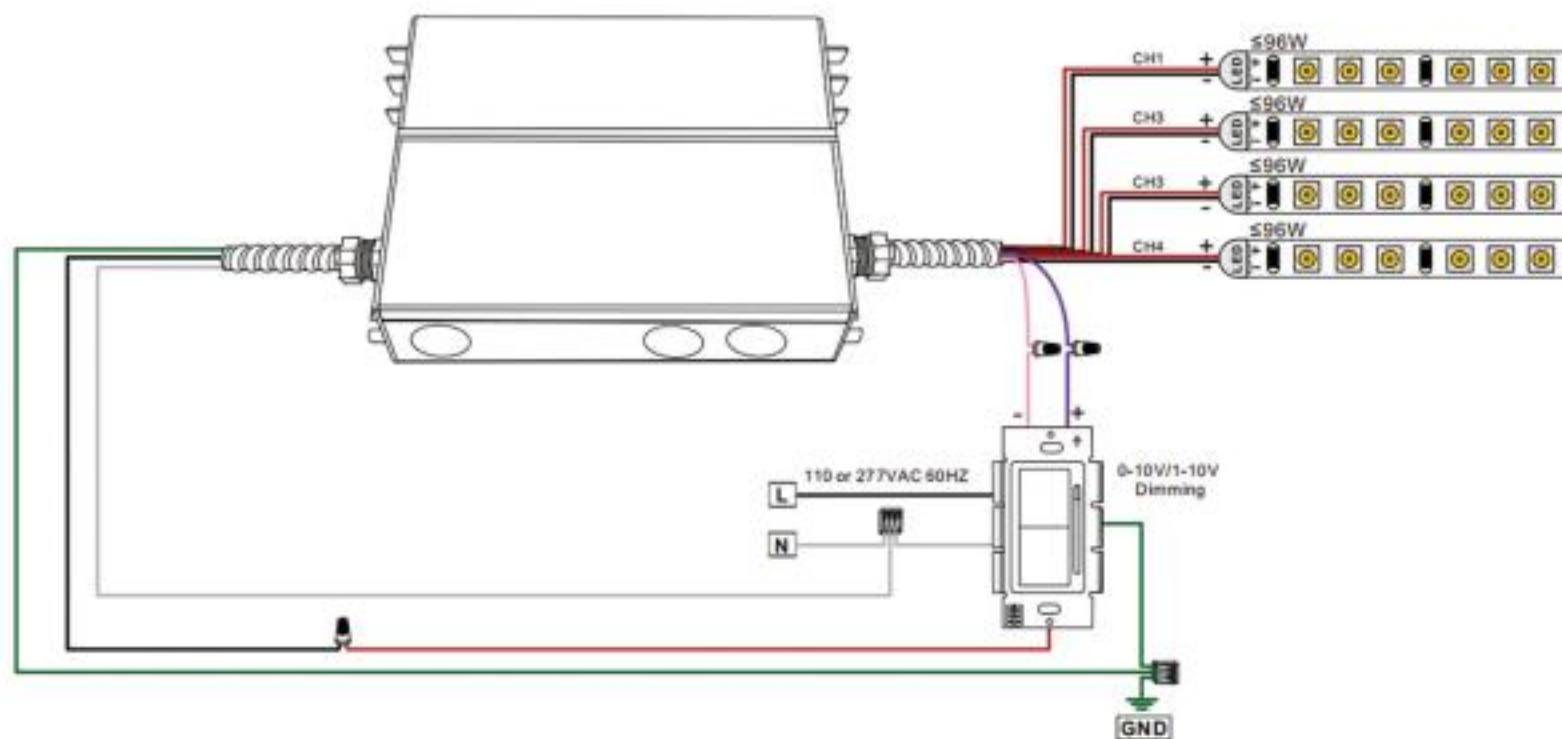

4) Using 0-10V/1-10V Dimming(The drive is independently connected to the input)

使用0-10V/1-10V调光 (驱动器独立连接输入)

